



DATE	
PROJECT	
TYPE	
NOTE	
PREPARED BY	

XLG-CLW-3031 **XLG-CLW-3031 Induction Full Cut-Off Wall Pack**



- Lamp Rating: 100,000 Hours for enhanced safety and maintenance
- Lumen Maintenance: 88% over 100,000 Hours
- Energy Savings: Over 57% savings comparing to HPS and other HID sources
- UL listed for wet location
- Light Output: 5000K, 90 CRI
- Voltage: 120-277v standard, 480 optional
- Applications: Parking areas, Tunnels, Railways, corridors
- Warranty: 10 year warranty (see terms and conditions)
- Construction: Heavy duty aluminum body, clear tempered glass

Lamp Specifications

Wattage	Lumens	CRI	Pupil Lumens	CCT(KELVIN)	Rated Life
XLG-CLW-3031-200IND	19,000	90	31,350	5000K	100,000 HRS

Ballast Specifications

System Wattage	Input Voltage	Input Current	Input Frequency	Power Factor	Operating-Temp	THD
210W	120-277VAC	1.75-0.76A	233KHz	.99	-31°F- 239°F	<10%

Ordering Guide

Example: (XLG-CLW-3031-200IND-47-120/277V-BZ-PC)

XLG-CLW-3031						
--------------	--	--	--	--	--	--

MODEL	WATTS	COLOR TEMP	VOLTAGE	MOUNTING	FINISH	OPTIONS
XLG-CLW-3031	200W-200IND	27-2700K 35-3500K 41-4100K 47-4700K 50-5000K 60-6000K	120-277V 480V	WALL MOUNT	BZ-BRONZE WH-WHITE CUS-CUSTOM	PC-PHOTO CELL MS-MOTION SEN- SOR DIM- DIMMING

*IC technology generator for power surge & spikes

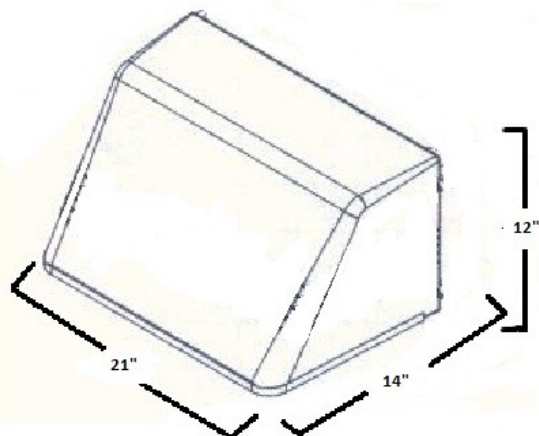

All our products are proudly manufactured and or assembled in USA and we are proud to announce that we are "BUY AMERICAN" compliant.